

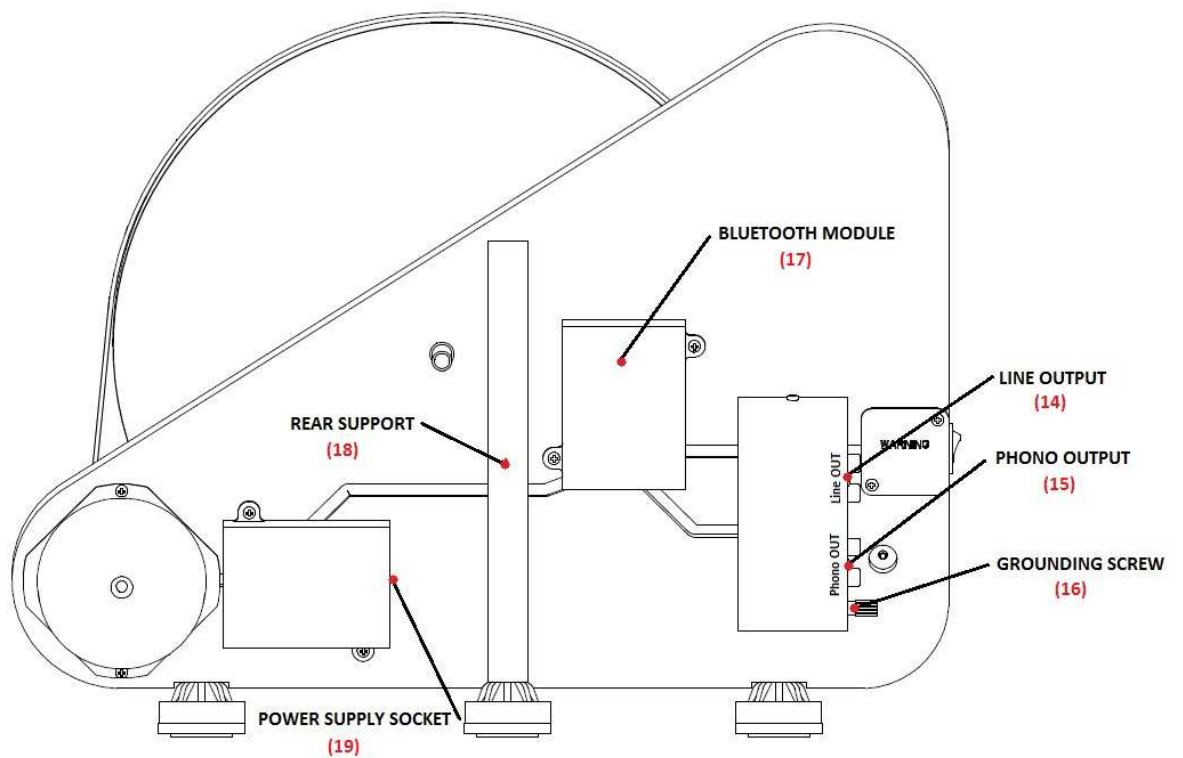

INSTRUCTIONS FOR USE
VT-E BT L

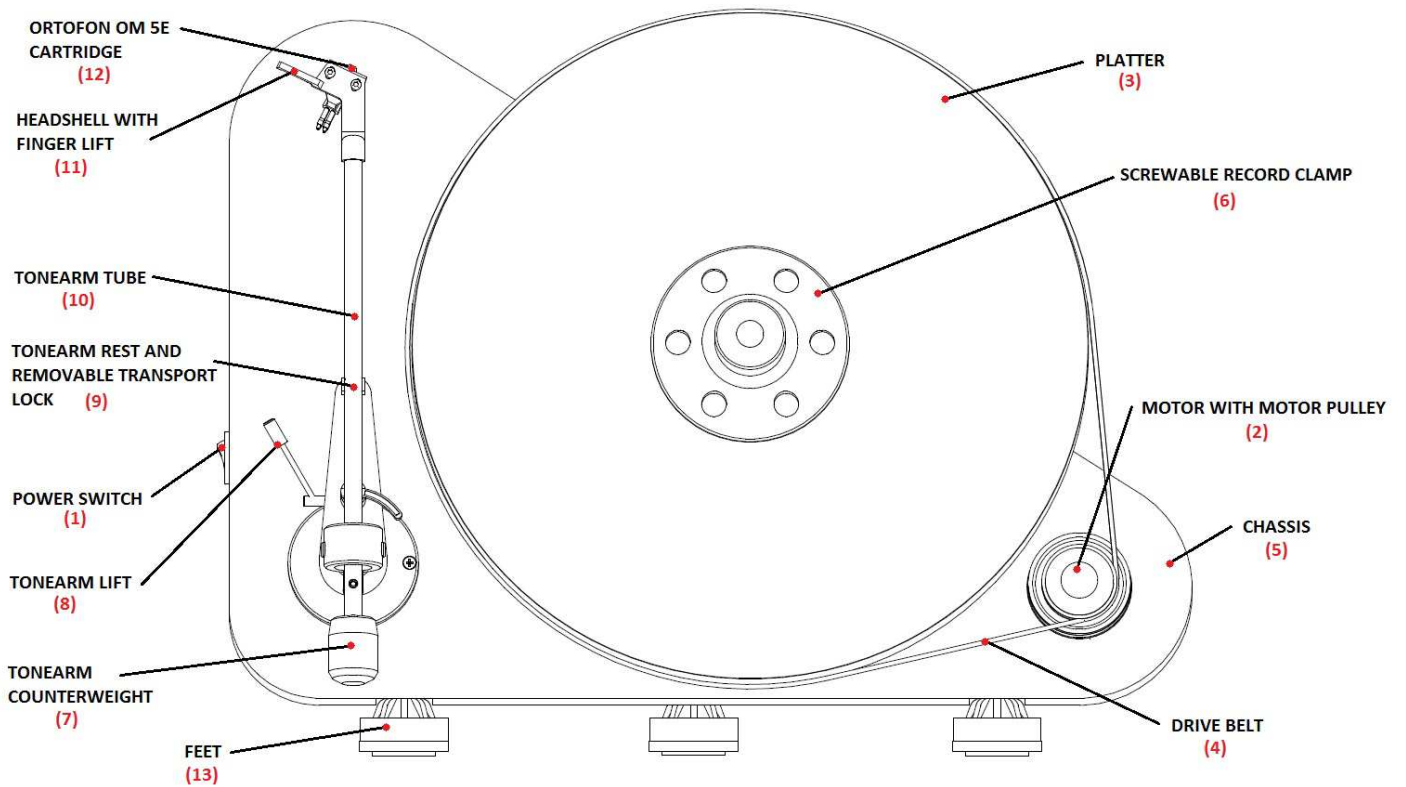

Mounting kit for wall mount

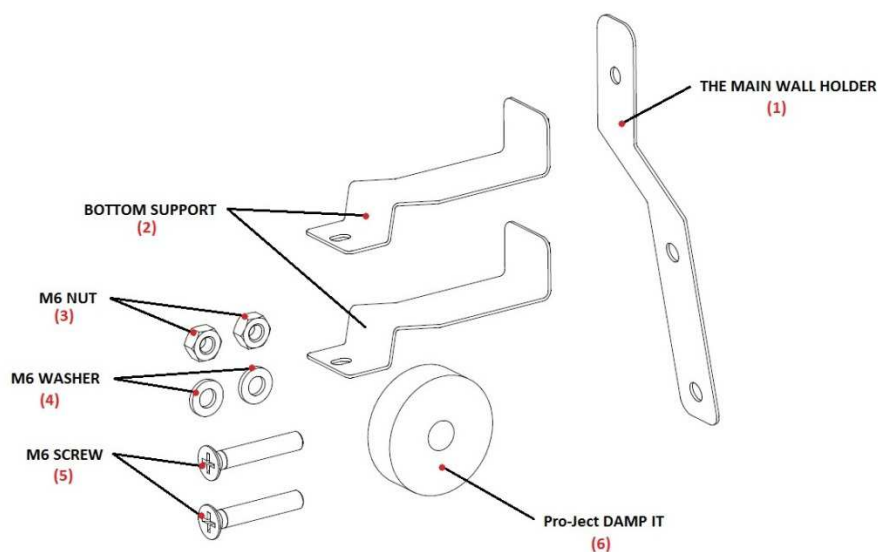

Pro-Ject
AUDIO SYSTEMS

VT-E BT L

Controls, features and connections

- (1) Power switch
 - (2) Motor with motor pulley
 - (3) Platter
 - (4) Drive belt
 - (5) Chassis
 - (6) Screwable record clamp
 - (7) Tonearm counterweight
 - (8) Tonearm lift
 - (9) Tonearm rest and removable transport lock
 - (10) Tonearm tube
 - (11) Headshell with finger lift
 - (12) Ortofon OM 5E cartridge
 - (13) Feet
 - (14) Line Output
 - (15) Phono Output
 - (16) Grounding screw
 - (17) Bluetooth module
 - (18) Rear support
 - (19) Power supply socket
- Universal power supply (not shown) *
Single adapter (not shown) *
Allen key (not shown) *

Mounting kit for wall mount

- (1) The main wall holder
- (2) Bottom support 2x
- (3) M6 nut 2x
- (4) M6 washer 2x
- (5) M6 x 35 screw for rear support or main wall holder
- (6) Pro-Ject DAMP IT

Packaging overview

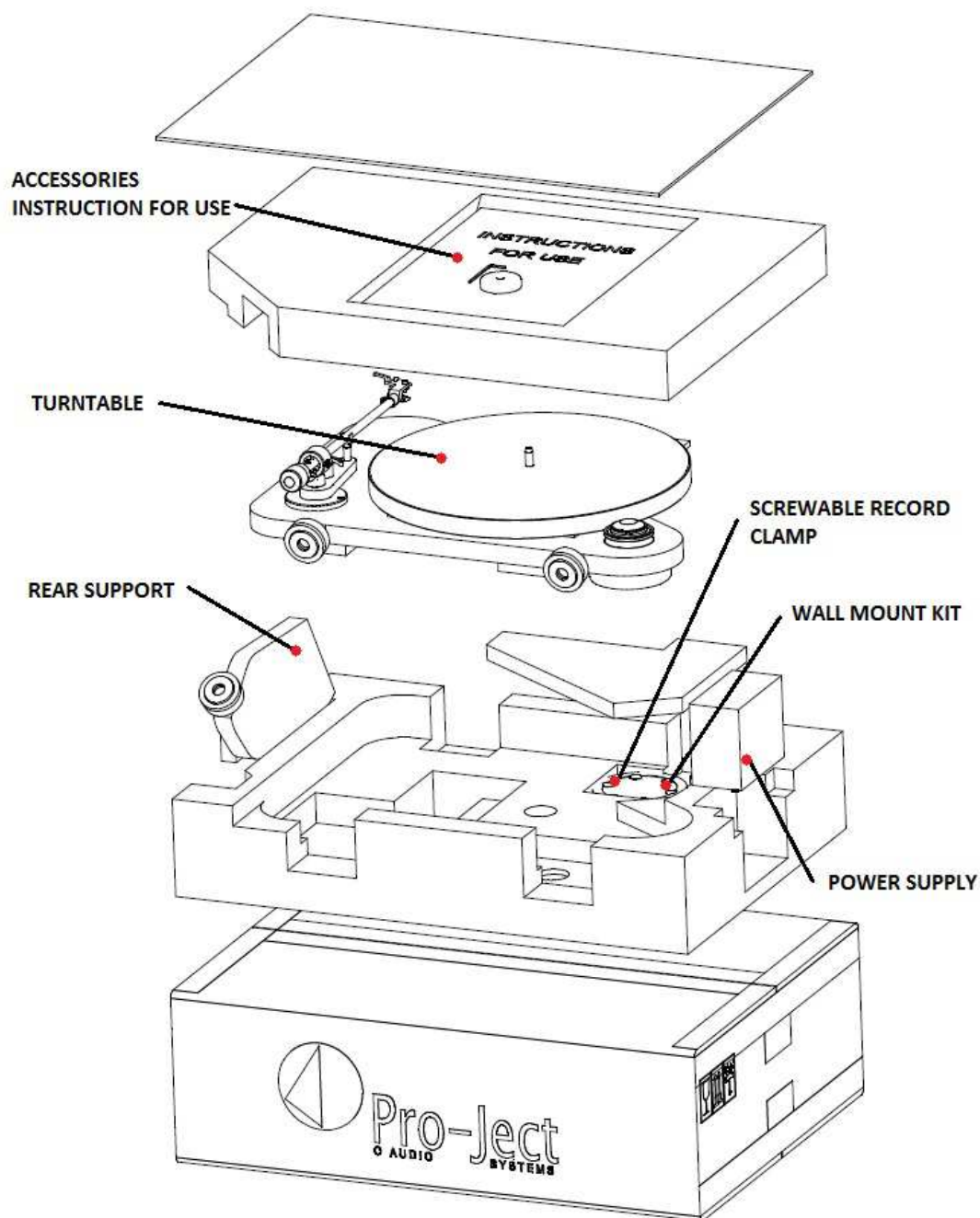

CONTENTS

TURNTABLE and ACCESSORIES overview	2 - 4
MOUNTING KIT and PACKAGING overview	4

SETUP AND INSTALLATION

PART 1 - DESKTOP MOUNT

1. ASSEMBLING THE REAR SUPPORT	7
2. MOUNTING THE PLATTER, DRIVE BELT AND THE RECORD CLAMP	7
3. CARTRIDGE, VERTICAL TRACKING FORCE (VTF)	8
4. CONNECTION TO THE AMPLIFIER	
5. BLUETOOTH PAIRING	8
6. MAINS POWER CONNECTION	8
7. SWITCHING ON AND OFF	8
8. CHANGING REPLAY SPEED	9
9. MAINTENANCE AND CLEANING	9

PART 2 - WALL MOUNT

10. DISASSEMBLING THE REAR SUPPORT	9
11. ASSEMBLING THE MAIN WALL HOLDER	10
12. ASSEMBLING THE BOTTOM SUPPORT	10
13. MOUNTING ON THE WALL	11
14. MOUNTING THE PLATTER, DRIVE BELT AND RECORD CLAMP	11

TECHNICAL SPECIFICATIONS	12
--------------------------	----

WARRANTY, SERVICE	12 - 13
-------------------	---------

Dear music lover,

Thank you for purchasing a Pro-Ject Audio Systems record player.

In order to achieve maximum performance and reliability, please study these instructions carefully.



Warning of a hazard for the user, the unit or possible misuse



Important notice

During assembling and adjustment small parts could be lost if they are not carefully placed in a suitable receptacle. Before starting assembly make yourself acquainted with the parts listed above which are correspondingly numbered in the technical drawings above. Separately packed items are marked with an asterisk *.

Safety instructions

The power supply is used to connect and disconnect the unit from the mains. Make sure that the plug is easily accessible at all times. Hold the plug when unplugging the power cord. Never handle the power cord while your hands are wet or damp.



Avoid letting liquids enter the device. Never place any item containing liquid, like a flower vase, on or near the device. Never spill any liquid on the device. Never place any naked flame sources, like lighted candles, on or near the device. The product shall not be used in damp or wet locations, next to a bathtub, sink, swimming pool or any other similar conditions.

Keep plastic bags away from children to prevent any risk of suffocation.



The turntable was shipped partially disassembled in order to avoid damage to sensitive parts. Please check immediately to make sure that neither the packaging nor the device was damaged in transit.

SETUP AND INSTALLATION

PART 1 – DESKTOP USE

1. ASSEMBLING THE REAR SUPPORT

Remove the rear support panel (18) from the packaging and prepare two M6x35 screws for mounting. Using the screwdriver, carefully tighten the screws to fix the rear support panel on the turntable's chassis (5) as shown in the following illustration.

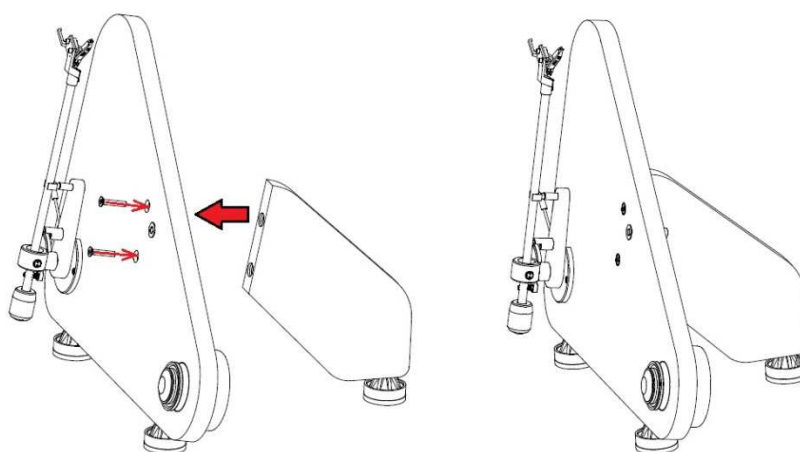

2. MOUNTING THE PLATTER, DRIVE BELT AND RECORD CLAMP

With the rear support (18) mounted and the turntable in vertical position, install the platter (3) and the drive belt (4) as shown in following illustration.

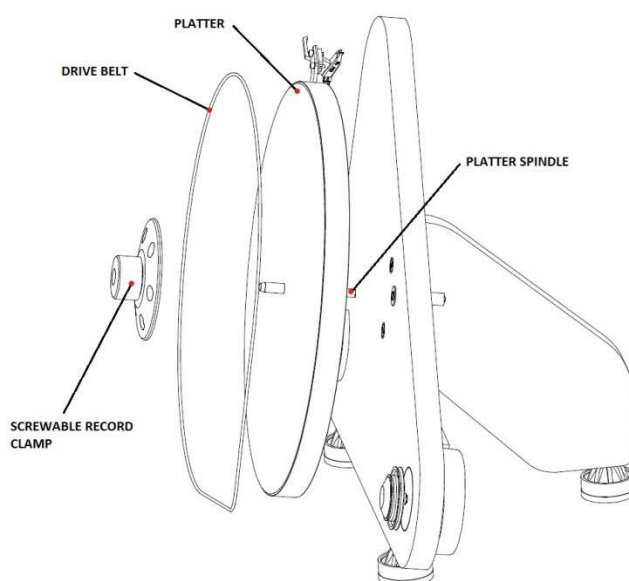

After placing the record on the platter, it is necessary to tighten the screw-able record clamp (6) onto the platter spindle.

3. CARTRIDGE, VERTICAL TRACKING FORCE (VTF)

The turntable is supplied with fitted cartridge Ortofon OM 5E. The counterweight (7) supplied is suitable only for Ortofon OM cartridges. Cartridge downforce is pre-adjusted from the factory.



Please note: It is not recommended to change the cartridge or vertical tracking force without prior consultation with your dealer.

4. CONNECTION TO THE AMPLIFIER

The record player has two possible outputs – **Line OUT (14)** with integrated preamplifier and **Phono OUT (15)** for connection to the preamplifier. If you choose **Phono OUT (15)**, then use the **Phono** input (sometimes labelled gram, disc or RIAA) on your amplifier. Make sure that the phono input offers correct matching and amplification for the type of cartridge used. If you choose **Line OUT (14)**, then use the **Line** inputs (like CD, Tuner, Tape or Video).

Take care about connecting the left and right channel correctly. The **RIGHT CHANNEL** is usually marked **RED**, the **LEFT CHANNEL** **BLACK** or **WHITE**. Check the manual of your amplifier for relevant information. An earthing wire may be connected to the screw terminal between the sockets if you encounter humming problems.

For detailed product information regarding Pro-Ject Audio Systems interconnect cables, phono amplifiers and stereo power amplifiers, please visit our website: www.project-audio.com

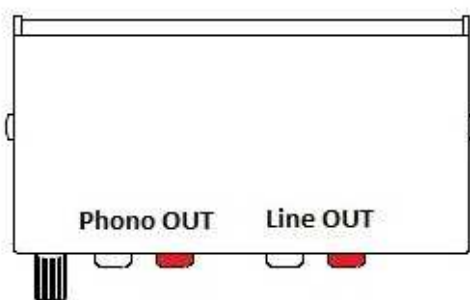

5. BLUETOOTH PAIRING

The record player has Bluetooth output and transmit signal automatically when is connected to mains.

It is paired automatically with any device with Bluetooth receiver (such as Pro-Ject MaiA, MaiA DS, Bluetooth Box s and Bluetooth Box E).

For pairing with other devices and portable speakers use the manual of the given product.

For restart of the Bluetooth transmitter, please disconnect the record player from mains. Restart is needed only when there is a change of the Bluetooth receiver.

For detailed product information regarding Pro-Ject Audio Systems Bluetooth audio receivers, please visit our website: www.project-audio.com

6. MAINS POWER CONNECTION

The turntable is supplied with a power supply suitable for your country's mains supply. Check the label before connecting to ensure compliance with the mains rating in your house.



Connect the low voltage plug from the power supply to the socket (19) on the rear of the record player before connecting the power supply to the mains.

7. SWITCHING ON AND OFF

Pressing the power switch (1) alternately starts or stops the motor.

8. CHANGING REPLAY SPEED

To play records at **45 r.p.m.**, put the drive belt **(4)** over the larger diameter part of the motor pulley **(2)**. To revert to **33 r.p.m.** repeat the proceedings using the smaller step on the pulley.

9. MAINTENANCE AND CLEANING

Your record player requires little or no regular maintenance. Remove dust with a slightly moistened antistatic cloth. Never use a dry cloth because this will create static electricity which attracts even more dust! Antistatic cleaning fluids are available at specialized stores but must be applied sparingly to avoid damage to rubber parts. It is recommended to fit the needle cover before cleaning or maintenance to avoid damage.

If the player is not used over a long period of time, the drive belt should be removed to prevent unequal stretching.



Always disconnect the record player from the mains power supply as a precaution before maintenance!

PART 2 – WALL MOUNT

10. DISASSEMBLING THE REAR SUPPORT

Remove two M6 screws which holds the rear support **(18)** in the back of the turntable.

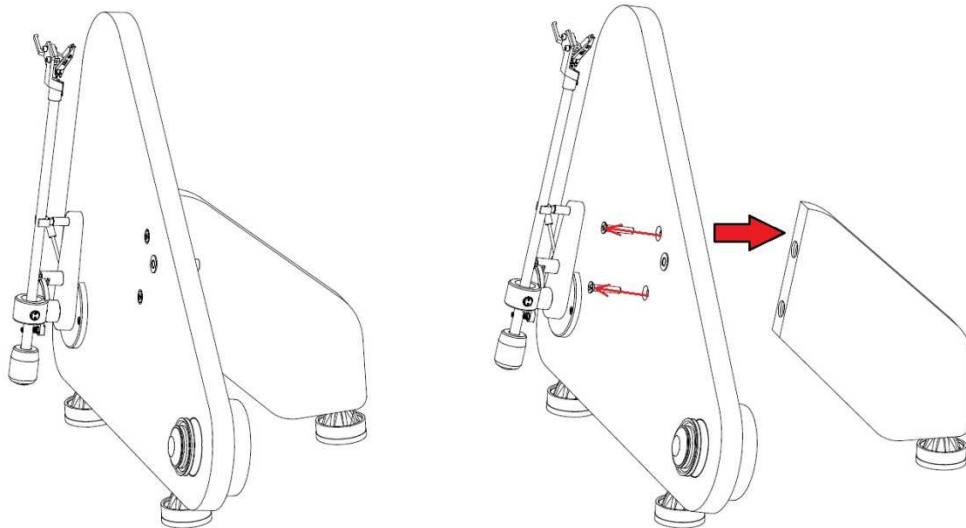

11. ASSEMBLING THE MAIN WALL HOLDER

For wall mount it is necessary to mount the main wall holder (1 – mounting kit) instead of the rear support (18). For correct mounting, follow instructions from next illustration.

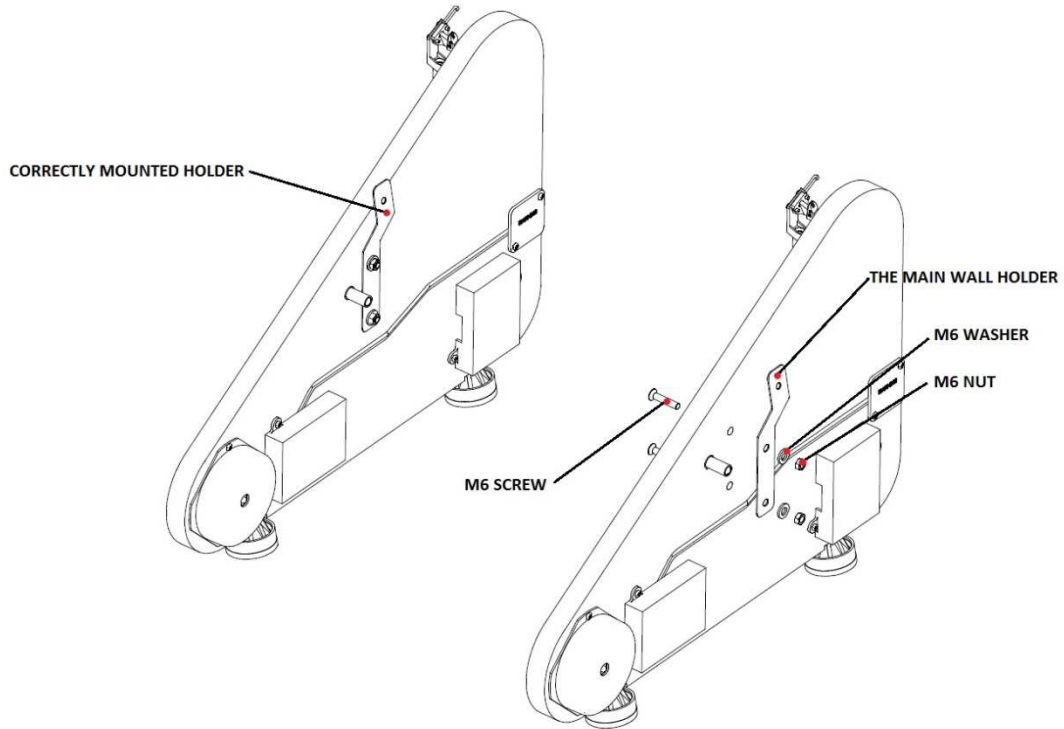

12. ASSEMBLING THE BOTTOM SUPPORT

With the main wall holder mounted on the turntable, unscrew both feet (13) from the bottom and instead of the feet screw the bottom support (2 – mounting kit) as shown in the following illustration.

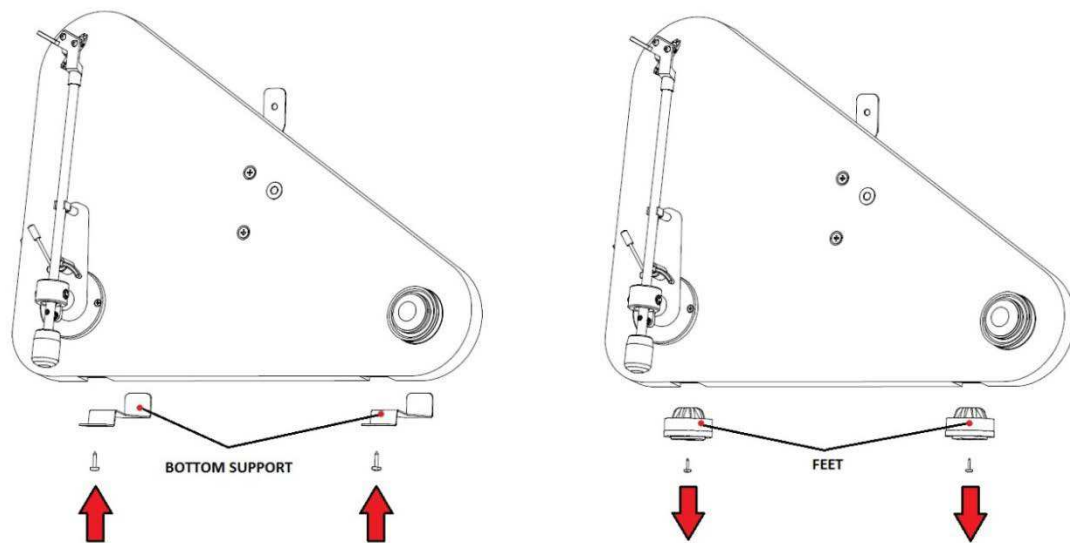

Now the VT-E is ready for mounting on the wall.

13. MOUNTING ON THE WALL

Mount the turntable on the wall through supplied damping pad Pro-Ject Damp IT.

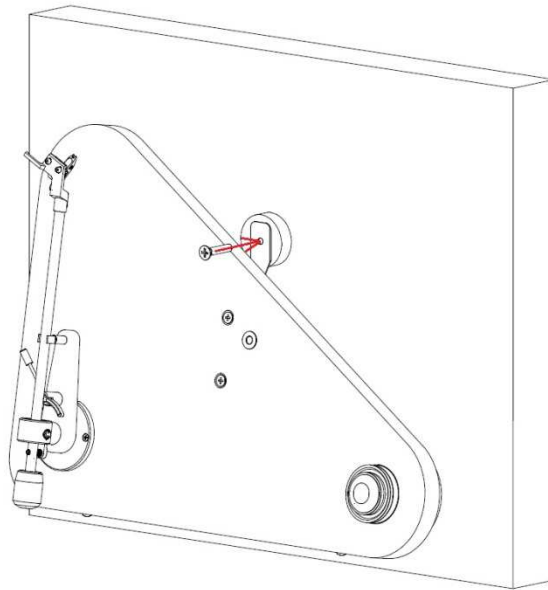

We recommend using the appropriate type of mounting screw for given type of the wall.

14. MOUNTING THE PLATTER, DRIVE BELT AND RECORD CLAMP

With the turntable mounted on the wall, install the platter (3) and the drive belt (4) as shown in following illustration.

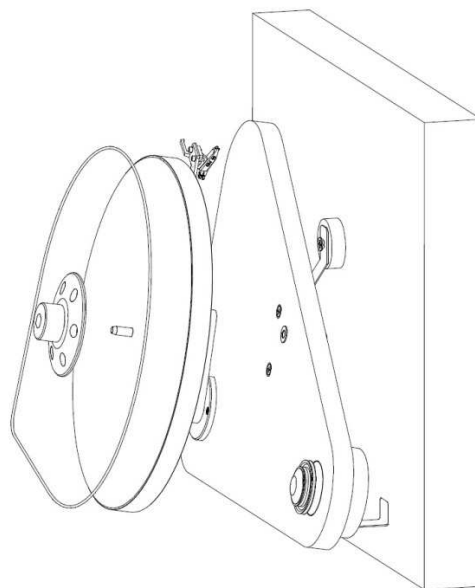

After the placing the record on the platter, it is necessary to tighten the screw-able record clamp (6) onto the platter spindle.

Technical specifications Pro-Ject VT-E BT L / Pro-Ject 8,6'' EV tonearm

Nominal speeds	33/45 r.p.m.
Speed variance	33: $\pm 0,80\%$ 45: $\pm 0,70\%$
Wow and flutter	33: $\pm 0,29\%$ 45: $\pm 0,27\%$
Signal to noise	65dB
Effective tonearm mass	8g
Effective tonearm length	8,6 " (218,5mm)
Overhang	22mm
Power consumption	4,5W (5W max)/ >0,5W standby mode
Outboard power supply	15V/ 0,8 A DC, universal power supply
Dimensions (W x H x D)	430 x 345 x 245mm
Weight	2,8 kg

Technical specifications MM-Cartridge Ortofon OM 5E

Frequency range	20-25.000Hz
Channel separation	22dB/1kHz
Output voltage	4mV
Recommended load impedance	47kohms/amplifier connection – MM-input
Compliance/stylus type	20 μ m/mN – elliptical
Recommended tracking force	17,5mN
Weight	5g

Potential incorrect use and fault conditions

Pro-Ject turntables are manufactured to the highest standards and undergo strict quality controls before leaving the factory. Faults that may possibly occur are not necessarily due to material or production faults but can sometimes be caused by incorrect use or unfortunate circumstances. Therefore the following list of common fault symptoms is included.

The platter doesn't turn although the unit is switched on:

- The unit is not connected to the mains power supply.
- No mains at the socket.
- Drive belt is not fitted or has slipped off.

No signal through one or other channel or both channels:

- No signal contact from the cartridge to the internal tonearm wiring or from that to the arm lead or from that to the phono box or between that and the amplifier. This could be due to a faulty plug, broken wire or solder joint or simply loose plug/socket connection.
- Phono input not selected at amplifier.
- Amplifier not switched on.
- Amplifier or speakers defective or muted.
- No connection to the loudspeakers.

Strong hum on phono input:

- No earth connection from cartridge or arm or arm cable to amplifier, or earth loop.

Distorted or inconsistent sound from one or both channels:

- Record player is connected to wrong input of amplifier, or MM/MC switch incorrectly set.
- Needle or cantilever damaged.
- Wrong r.p.m., drive belt overstretched or dirty, platter bearing without oil, dirty or damaged.

Service

Should you encounter a problem which you are not able to alleviate or identify despite the above information, please contact your dealer for further advice. Only when the problem cannot be resolved there should the unit be sent to the responsible distributor in your country.

Guarantee repairs will only be affected if the unit is returned correctly packaged. For this reason we recommend keeping the original packaging.

Never return a record player without making sure that it is safely disassembled and correctly packaged in the original packaging according to the diagrams on the last page of this user guide.

Fit the cartridge protection cap and the transport lock for the tonearm tube, prior to carefully packaging the record player.

Warranty



The manufacturer accepts no responsibility for damage caused by not adhering to these instructions for use and/or by transportation without the original packaging. Modification or change to any part of the product by unauthorized persons, release the manufacturer from any liability over and above the lawful rights of the customer.

Pro-Ject Audio Systems is a Registered Trademark of H. Lichtenegger.

This guide was produced by: Pro-Ject Audio Systems
Copyright © 2016. All rights reserved.

The information was correct at the time of going to press. The manufacturer reserves the right to make changes to the technical specification without prior notice as deemed necessary to uphold the ongoing process of technical development.